



Up Top In Operations

January 2005

Monthly Newsletter of the National Operations Department

Volume 01

A Big Month for AUXAIR Bob Shafer, DVC-OA

January is a big month for Auxiliary Aviation this year. As you will see in this issue of Up Top In Operations, we have some new names in the National AV Division. N-Train will be held at the end of the month in St. Louis, and the DSO-AVs will be gathering there to receive some training. Just prior to N-Train we will be presenting a C-School for AACs (Auxiliary Aviation Coordinators) and AUXLOs (active duty Auxiliary Liaison Officers) from the various Air Stations around the country. And we'll see the resumption of SD/CRM (Spatial Disorientation / Crew Resource Management) training at NAS Pensacola at the end of the month. Whew!

I'll start at the end of this list with a mention of the SD/CRM training in Pensacola. When the hurricanes blew through Florida last fall, NAS Pensacola suffered extensive damage. Our SD/CRM training was cancelled, and it was unclear when, or even if, it would resume. I'm very pleased to say that will resume this month, and a schedule of classes has been published for the next nine months. Now Auxiliary aviators can make plans to attend more than just a few weeks in advance.

That's important for those of us who have to coordinate vacation time away from those pesky "real life" jobs.

Ken Summers, an Aircraft Commander from 9ER, wrote a first hand account of attending the first SD/CRM session, for this issue of Up Top, to give you an idea of what to expect. If you haven't yet attended, get your request in as soon as possible in order to get assigned to the class you want. Remember, all Auxiliary pilots must have this training by the end of 2006.

The National AV staff has been keeping busy getting ready for the two events in St. Louis: N-Train and the AAC/AUXLO National "C" School. In a jam packed couple of days, most of the folks responsible for the management and operational oversight of the AUXAIR program will gather to learn and share ideas. We'll go over all of the various (and sometimes arcane) regulations and instructions which govern the AV program, and all of the many changes which have occurred in the past year or so. We'll have some practical, nuts and bolts, training on various aspects of managing the program, and there will be ample opportunity for attendees to get

their questions answered. We're very pleased that the AACs and AUXLOs will be able to attend this, the first school for those folks.

We have a few new staff members I'd like to introduce to you, and we've been saddened by the loss of another. Dr. Robert Poole, our Branch Chief, Air Flight Surgeon, passed away on December 14, 2004. Dr. Bob was one of the top aerospace medicine doctors at the FAA, and we were very fortunate to have him on our staff. He was an advocate for common sense in airman medical certification regulations, and regularly gave insightful advice to the Coast Guard on medical requirements for aviators. He assisted many

Auxiliary Aviators with advice and answers to their medical certification questions.



Steve Kokkins makes his Up Top debut in this issue. Steve is a DFSO in 1NR and is our new Branch Assistant for Aviation Training. We also have a new Branch Chief for Aviation Training, Mike Belica.

Continued on page 3

Aircrew Spatial Disorientation Training

Ken Summers, 9CR

In November, 2003, I had an opportunity to attend the first session of the Spatial Disorientation Course required of all auxiliary aviators at the Pensacola Naval Air Station in the panhandle of Florida. Travel by AUXAIR or commercial airline was authorized. What to do?

Winter flying in the Great Lakes and Ohio Valley can be an adventure. However, Wes Snyder from 9 Central and I picked a great day to fly. We probably came no closer than 20 miles to the cold front and its associated clouds and icing that had passed the previous evening. The frontal passage assured us of a nice tailwind, so our magic carpet Mooney Ovation cruising at 10,000 feet had us landing at Pensacola Regional Airport after a flight time of three hours and thirty-eight minutes from Cleveland, Ohio thanks to a ground speed of 210-215 knots. We were not permitted to land at the NAS which was unfortunate. High density training flights in a variety of high performance aircraft and the Blue Angels practicing in the area must have made the Navy a little nervous. Regional was an inconvenient half hour cab ride to the NAS which meant we had to clear security at the main gate.

We checked into the Navy Lodge on base and lucked out with good rooms, and the lodge is just above a beautiful beach. Our big mistake was using a taxi to get to NAS instead of renting a car. This is a large facility and getting around is difficult without wheels. There was no base taxi or bus service from the Navy Lodge unless you used commercial taxis. Chow at lunch time could be had at the Chief Petty

Officers' Club next to the Lodge and dinner was at the Officers' Club about a three quarter mile walk away. It was packed on Wednesday night, and some of the Angels were enjoying the free pizza. The simulator facility is a very long walk, again, a good reason to have a car.

A Navy corpsman (medic) gave the physiological training part of the SD program. The first couple hours were in the classroom where a spinning Barany Chair was used to great effect on those who volunteered. Strange things happen when your body is rotating and you move your head. Vertigo is one symptom wherein you can not tell what attitude your aircraft is in. For the non-pilot, that means you don't have a clue what the aircraft is doing unless you are using the aircraft instruments and are proficient in instrument flying. In fact, you probably THINK you have a clue, but you are likely to be wrong. This confusion is caused by cilia (the tiny hairs in the inner ear canals) moving as a maneuver starts, and then gradually going back to a neutral position as the aircraft stabilizes in an unusual attitude, perhaps a steep turn, dive or climb. This is likely what happened to John Kennedy, Jr. The biggest killer of pilots, especially in general aviation, is spatial disorientation after flying into low or no visibility conditions. This is why we must maintain proficiency in poor visibility or instrument meteorological conditions (IMC).



Continued on Page 4

Help Prevent Spatial Disorientation!

Bob Shafer, DVC-OA

How? Attend the SD/CRM training at NAS Pensacola. It's easy to apply, and it's excellent training, required of all Auxiliary pilots by the end of 2006. Pilots interested in attending should submit a Short Term Training Request following your District policies, to your DIRAUX. The DIRAUX will forward the requests to CHDIRAUX for addition to the class roster. The class schedule for the rest of the year is:

FEB 24-25
MAR 24-25
APR 28-29
MAY 19-20
JUN 23-24
JUL 28-29
AUG 25-26
SEP 28-29

There are a maximum number of students of 30 per class. However, we have 206 total quotas for FY05. So, if we use up all the quotas before the August and September classes, those classes will be canceled. Please pass the word that people should sign up for the earlier classes if they want to guarantee the course will be held.

And if you do sign up, remember, you are making a commitment and are expected to attend. If you sign up and must cancel, please do so in enough time that someone else may attend in your place.

Note: the Short Term Training Request Form (CG 5223) can be found at http://www.uscg.mil/ccs/cit/cim/forms1/FORMS/CG_5223.pdf or at cgaux.org.

Meet the Safety Guy!
Byron Moe, BC-OAS

I would like to take this opportunity to introduce myself. My name is Byron Moe, and I am the new Branch Chief for Auxiliary Air Safety. I have been a member of the Auxiliary since 1983, and have flown operationally for over 15 years. In real life I am a Captain/Instructor/Line Check Airman for Northwest Airlink flying the AVR-146-RJ85. I have accumulated some 16,000 flight hours, of which almost 1,000 of which are under Auxiliary orders. I have also been the Air Safety Chairman at my airline for over 15 years, and have worked in the National Safety Structure of the Air Line Pilots Association almost as long. During that time I have worked on the Regional Airline Committee, the One Level of Safety Project, numerous Master Minimum Equipment List committees, a number of Aviation Rulemaking Advisory Committees (ARAC), as well as a number of FAA & Industry Working Groups. One of the latest endeavors I worked on was the In-flight Icing Certification Project Team. We worked on rewriting CFR Title 14, Part 25 Certification Standards for Icing Conditions. I learned a great deal from this group, and I am going to pass along some of that to you a little later in this article.

So, I am the new kid on the staff. My goal is to have all our Auxiliary crews work in a safe and professional manner at all times. I hope to develop a web page that will provide a good deal of safety information for all crews and as serve as the primary point of contact for all crews on safety related issues. If you have questions or need some information please feel free to contact me at Byronmoe@aol.com.



Eventually I want to get out to all the areas and meet with crews, as well as helping to develop programs that will enhance the overall safety of the Air Program.

With all that said let me jump right into the safety side by providing you with some recent information on in-flight icing and tail-plane stalls. When called to go out on a Search and Rescue case, the weather is usually not a factor. Fall, winter, and spring month's in-flight icing can become a major factor in determining whether or not we can safely execute a flight. If your aircraft is not equipped with either deicing or anti-icing equipment, then the answer is a resounding NO. Even if you are equipped with the appropriate equipment, and your aircraft is certified for flight into known icing, you still need to evaluate the conditions and make a judgment of the risk involved. First, if you have an aircraft that is equipped with boots, check with your aircraft's manufacturer and determine the correct procedure for the operation of the deicing equipment on your aircraft.

Continued on page 5

A Big Month for AUXAIR

Continued from page 1

Mike has extensive professional experience in education as a college professor. He also has experience in aviation education in the airline environment. He's been in the Auxiliary for a long time and has held many offices, including DFSO. Frank Tangle is our new Branch Chief for Aviation Management. Frank has been around the Auxiliary for a while and brings his experience as a DSO-AV to the job. He also has considerable experience gained from working in industry. Our new Branch Chief for Aviation Safety, Byron Moe, introduces himself in these pages in the article he wrote for this issue of Up Top. Byron is a former active duty aviator and is now an airline pilot. But that's just the beginning. He lists some of his many qualifications in his article. Take a look and you'll see that he's a very good fellow to have on our team. Welcome aboard to all of our new AV staff members.



National Operations Department		
Program	Staff Member	E-mail Address
Department Chief	Linda A. Nelson	echopeep@verizon.net
Deputy Department Chief	David A. Elliot	DC-Od @auxop.us
Aids to Navigation	George A. Pendergast	comodone@charter.net
Aviation	Robert Shafer	DVC-OA@auxair.us
Communications	Edwin "Ned" Kroeker	ekroeker@seaqueue.com
Surface Operations	Mark Simoni	mark@simonisystems.com
Education	Aline (Lindy) Harrison	aharriso@ycp.edu
G-OCX Operations Division Chief	LCDR Mike Staier. USCG	MStaier@comdt.uscg.mil
G-OCX Aviation Branch Chief	LT Justin Harper. USCG	JHarper@comdt.uscg.mil
G-OCX Surface Operations Branch Chief	MCPO Gary Jensen, USCG	GJensen@comdt.uscg.mil

FLIGHT SAFETY ON THE RUN

Steve Kokkins, BA-OAT

Well, the weather is especially questionable at this time of year, and it's important for the Auxiliary pilot-in-command to keep up with it. You use current knowledge of these conditions in your Risk Assessment before flight, and could go, alter or cancel your plans as appropriate to insure the high level of safety and conservatism required for all Auxiliary missions. Here is an additional way to get some of the information you need.

After your briefing, pilots can get current airport weather info by phone, by calling the AWOS/ASOS/ATIS info numbers listed for each airport in their FAA-issued Airport Flight Directories (A/FD). Great for last-minute decision-making on your timing, route and destination conditions. No computers needed!



DISTRIBUTION:

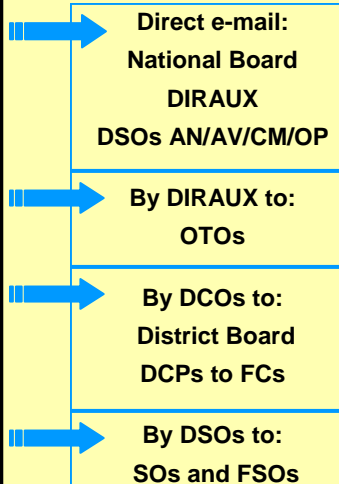

AIRCREW SPATIAL DISORIENTATION TRAINING

Continued from Page 2

After the classroom session, we went to the Spatial Disorientation Trainer, AKA the Spin and Puke machine. Don't worry about the wannabe fighter jock macho stuff. None of the 18 pilots in my group had any problem. The trainer is a large rotating disc about 15 or 20 feet in diameter. This disc has 10 can shaped cylinders that hold the trainee in an odd cockpit of sorts. The trainee is seated and strapped into the unit in front of a panel with lots of lights and a couple of numerical readouts similar to an aircraft's transponder. With a small joystick, the pilot will input movements indicating what he or she thinks the "aircraft" is doing based on the instructor's instructions and the light indications on the panel. The disc turntable and / or the cylinder "cockpit" can rotate singly or together and with or counter to each other to simulate various "aircraft" actions. During the entire time, an instructor will be talking to you through headphones, and you can stop the machine if you are very uncomfortable. Your body will pull against the harness as it would in actual flight conditions as the centrifugal force takes over. As I recall, the total time in the machine was about 20 minutes. The program was very instructive and worthwhile.

After completing the course, some of us visited the Museum of Naval Aviation that is located across the street from the Navy Lodge. Although the museum is not nearly as large as the U.S. Air Force Museum in Dayton, Ohio, it is a real gem that has to be seen. Represented is everything from a Blue Angels diamond formation suspended from the ceiling to the original NC-4 flying boat that crossed the Atlantic in 1919 to a bunch of cockpit procedures trainers for numerous fleet aircraft.

They even have some old Coast Guard aircraft. Also, Pensacola is a very nice place to spend a few days for those who may chose to do so.



The following morning, we headed for Regional airport, fueled up and departed for Cleveland. It was hard to believe, but we had a slight tailwind on the return. It was probably the first time I have ever had tailwinds in each direction. Like most pilots, usually I can count on a headwind or a strong crosswind. Less than four hours later we landed at Lorain County Regional Airport and headed home.

The next class after mine had a second day added, and training is now given in Crew Resource Management, another important aspect of flight safety. Maybe I'll apply again. Who knows! Maybe I'll spin and puke.

Editor's note: see Bob Shafer's article on "Help Prevent Spatial Disorientation" (found on page 2) to find a course offering for you!



Meet the Safety Guy

Continued from page 3

In the last few years NASA has determined that the old procedure of allowing appreciable accumulation prior to operating the deicing boots is not correct. Ice bridging has been determined to be a myth. After years of training otherwise this was hard for me to accept until I reviewed the available data. With this new information derived from wind tunnel and flight testing, the operational theory of deicing boots changed. Airworthiness Directives have been issued for a number of aircraft detailing new operating procedures for many larger aircraft, but I am not sure that all aircraft have been covered. I am hoping to contact Piper, Cessna, Cirrus, Grumman, Mooney, and Beechcraft to get a comprehensive list of their aircraft and recommended procedures. (OK, who did I leave out?)

So, you're out there and you begin to accumulate ice. First and foremost, GET OUT! Even if your aircraft is protected, and this includes hot wings too, do not linger in icing conditions. Ice can be insidious, and can collect in unexpected ways and behind protected surfaces, which is really, really bad! Tailplanes are much more efficient ice collectors than wings. If you are getting trace ice on a wing assume a greater accumulation is occurring on the tail. Tailplanes are basically inverted wing surfaces, so they will react differently than the wing. Very little has been published on tailplane icing issues, especially on the area of tailplane stalls. Please take a look at the procedure in the attached sidebar. Remember, the Auxiliary Operations Policy Manual prohibits flights under orders in areas of forecast icing conditions.



ICE CONTAMINATED TAILPLANE STALL (ICTS)

DETECTION PROCEDURES

On some airplane designs, if the horizontal tailplane is inadequately cleared of ice, either by anti ice/de ice system failure, failure to operate the system properly, or by adverse residual ice accumulation on critical sections of the airfoil, a tailplane stall could occur. Tailplane stall would generally be encountered immediately after extension of the trailing edge flaps to an intermediate position or most commonly from an intermediate position to a full down position. Tailplane stall (or impending stall) can usually be identified by one or more of the following symptoms being exhibited during or after flap extension. The symptom(s) may occur immediately, or after nose down pitch, speed or power increases following flap extension:

- Elevator control pulsing, oscillations, or vibrations
- Abnormal nose down trim change
- Other pitch anomalies possibly resulting in pilot induced oscillations (PIO)
- Reduction of elevator effectiveness

NOTE: The above indications may not be detected if the autopilot is engaged

- Sudden elevator force change (control would move nose down if unrestrained) followed

AVOIDANCE PROCEDURES

1. Follow manufacturer's recommendations regarding flap deployment with ice accreted on the airframe.
2. Consult the Minimum Equipment List (if available) in the event of enroute ice protection system failure. Follow MEL requirements regarding minimum airspeeds, flap deployment, and all other procedures in the event of a full or partial ice protection system failure.
3. For planning purposes, consider that the tailplane is probably a more efficient collector of ice than the main wing. Therefore, ice accretion judged to be moderate on the main wing may

be severe on the tail.

4. Do not plan an approach using higher than normal descent rates for the purpose of minimizing icing exposure.

RECOVERY PROCEDURES

If any of the tailplane stall symptoms are exhibited with ice accretion known or suspected:

1. Immediately retract the flaps to the previous setting and apply appropriate nose up elevator.
2. Increase airspeed APPROPRIATE FOR THE REDUCED FLAP SETTING.
3. Apply sufficient power for configuration and conditions. High engine power settings may be adverse to tailplane stall conditions on some designs at high airspeed.
4. Make nose down pitch changes slowly - even in gusting conditions, IF circumstances allow.
5. If a pneumatic de-icing system is installed on the tailplane, operate the system several times in an attempt to clear the tailplane of ice.
6. Avoid uncoordinated flight if possible (i.e. rudder induced sideslip), it may aggravate tailplane stall.

WARNING

ONCE ICE CONTAMINATED TAILPLANE STALL IS ENCOUNTERED, THE STALL CONDITION TENDS TO WORSEN WITH INCREASED AIRSPEED AND POSSIBLY INCREASED POWER SETTING AT THE SAME FLAP SETTING. AIRSPEED AT ANY FLAP SETTING IN EXCESS OF THE AIRPLANE MANUFACTURER'S RECOMMENDATIONS FOR THE FLIGHT AND ENVIRONMENTAL CONDITIONS, ACCOMPANIED BY UNCLEARED ICE CONTAMINATING THE TAILPLANE, MAY RESULT IN A TAILPLANE STALL AND UNCOMMANDED PITCH DOWN FROM WHICH RECOVERY MAY NOT BE POSSIBLE. TAILPLANE STALL MAY OCCUR AT SPEEDS LESS THAN V_{FE} .